

3GPP TR 23.917V1.2.0 (2004-01)

Technical Report

3rd Generation Partnership Project; Technical Specification Group Services and System Aspects; Dynamic Policy control enhancements for end-to-end QoS; (Release 6)



The present document has been developed within the 3rd Generation Partnership Project (3GPP™) and may be further elaborated for the purposes of 3GPP.

The present document has not been subject to any approval process by the 3GPP Organizational Partners and shall not be implemented. This Specification is provided for future development work within 3GPP only. The Organizational Partners accept no liability for any use of this Specification. Specifications and reports for implementation of the 3GPP™ system should be obtained via the 3GPP Organizational Partners' Publications Offices.

Remove GSM logo from the cover page for pure 3rd Generation documents.

Select keywords from list provided in specs database.

Keywords

<keyword[, keyword]>

3GPP

Postal address

3GPP support office address
650 Route des Lucioles - Sophia
Antipolis
Valbonne - FRANCE
Tel.: +33 4 92 94 42 00 Fax: +33
4 93 65 47 16

Internet

<http://www.3gpp.org>

Copyright Notification

No part may be reproduced except as authorized by written permission.
The copyright and the foregoing restriction extend to reproduction in all media.

© 2002, 3GPP Organizational Partners (ARIB, CWTS, ETSI, T1, TTA, TTC).
All rights reserved.

Contents

1	Scope	5
2	References.....	5
3	Definitions, symbols and abbreviations	5
3.1	Definitions	5
3.2	Symbols	5
3.3	Abbreviations.....	5
4	Introduction	6
5	Background	6
6	Objectives	7
7	Architecture.....	9
7.1	Introduction.....	9
7.2	Description of functional entities	9
7.2.1	Gateways	9
7.2.2	PDF.....	9
7.2.3	Application Function.....	9
7.3	Relationship between functional entities	9
7.4	Functions with Policy Control	10
7.4.1	Authorise QoS resources	10
7.4.2	Exchange of information for charging correlation	12
7.4.3	Enable media	12
7.4.4	Disable media	12
7.4.5	Revoke authorisation.....	13
7.4.6	Indicate bearer release/failure	13
7.4.7	Confirm bearer reservation.....	13
7.5	Description of interfaces	14
8	Information flows.....	14
8.1	General operation of Gq interface	15
8.2	Example usage with IMS	15
8.2.1	IMS Session setup.....	15
8.2.2	IMS Session teardown	16
8.3	Authorisation of session QoS resources.....	17
8.3.1	Authorisation of QoS resources, session establishment.....	18
8.3.2	Authorisation of QoS resources, bearer establishment, and exchange of information for charging correlation	20
8.3.3	Example of authorisation of QoS resources and exchange of information for charging correlation, P-CSCF is Application Function	21
8.4	Approval of QoS commit	22
8.4.1	Example of approval of QoS Commit, P-CSCF is Application Function	23
8.5	Authorisation of modification of network resources	23
8.5.1	Authorisation of network resources modification, PDP context modification to IMS	24
8.6	Indication of network resources events	25
8.6.1	Indication of network resources modification, PDP context modification to IMS	25
8.7	Revoke Authorization for the session.....	26
8.7.1	Revoke Authorization for the session, Application Function initiated.....	26
8.7.2	Revoke Authorization for the session, PDF initiated	26
8.7.3	Revoke for IMS Session release, P-CSCF is Application Function, P-CSCF initiated.....	27
8.8	Update Authorization for the session.....	27
8.9	Removal of QoS commit	28
8.9.1	Removal of QoS Commit, P-CSCF is Application Function	29
8.10	Indication of network resources removal.....	29
8.10.1	Indication of network resources removal, PDP context release to IMS	30

9	Function Requirements	30
10	Example of rel6 policy control usage with a PSS application and GPRS IP- Connectivity Network	31
10.1	Per User Authorisation.....	32
10.2	Resource reservation	33
10.3	Session Release	33

Foreword

This Technical Report has been produced by the 3rd Generation Partnership Project (3GPP).

The contents of the present document are subject to continuing work within the TSG and may change following formal TSG approval. Should the TSG modify the contents of the present document, it will be re-released by the TSG with an identifying change of release date and an increase in version number as follows:

Version x.y.z

where:

x the first digit:

1 presented to TSG for information;

2 presented to TSG for approval;

3 or greater indicates TSG approved document under change control.

y the second digit is incremented for all changes of substance, i.e. technical enhancements, corrections, updates, etc.

z the third digit is incremented when editorial only changes have been incorporated in the document.

1 Scope

This document studies how the policy control is used for IMS and interacts with the appropriate IMS and non-IMS application servers. This document investigates the feasibility of the interface between the PDF and application entities (e.g. P-CSCF in the IM domain). The feasibility study determines the requirements and architecture for this work.

2 References

The following documents contain provisions which, through reference in this text, constitute provisions of the present document.

- References are either specific (identified by date of publication, edition number, version number, etc.) or non-specific.
- For a specific reference, subsequent revisions do not apply.
- For a non-specific reference, the latest version applies. In the case of a reference to a 3GPP document (including a GSM document), a non-specific reference implicitly refers to the latest version of that document *in the same Release as the present document*.

- [1] 3GPP TR 21.905: "3G Vocabulary".
- [2] 3GPP TS 23.002: "Network Architecture".
- [3] 3GPP TS 23.207: "End to end Quality of service concept and architecture".
- [4] 3GPP TS 29.207: " End to end Quality of service (QoS); stage 3".

3 Definitions, symbols and abbreviations

For the purposes of the present document, the terms and definitions given in [1] and the following apply.

3.1 Definitions

3.2 Symbols

3.3 Abbreviations

For the purposes of the present document, the following abbreviations apply:

ABC Axxx Bxxx Cxxx

Other abbreviations used in the present document are listed in 3GPP TR 21.905 [1].

4 Introduction

In release 5, the service-based local policy control provides a way to manage the GPRS access network through dynamic policies over the Go interface.

The release 5 IMS work uses a policy decision function (PDF) that is only applicable for IMS and tightly linked to the SIP session control. This does not enable a generic service policy to be applied to both IMS and non-IMS services.

Within Release 5 the PDF is shown as being a logical entity of the P-CSCF. Standardising the interface between the PDF and application entities (e.g. P-CSCF in the IM domain) was pushed back to release 6.

In this document the means by which policy control is used for IMS and interacts with the appropriate IMS and non-IMS applications, is studied.

The objectives are to:

- Enable general policy control over IP bearer resources and SIP services to evolve separately.
- Enable more flexibility in engineering and policy control of IP bearer resources.
- De-couple policy functions from IMS entities.
- De-couple Application functions from IP-Connectivity Networks.

5 Background

As shown in figure 1, in release 5, the IM Subsystem is closely coupled with the UMTS Core Network.

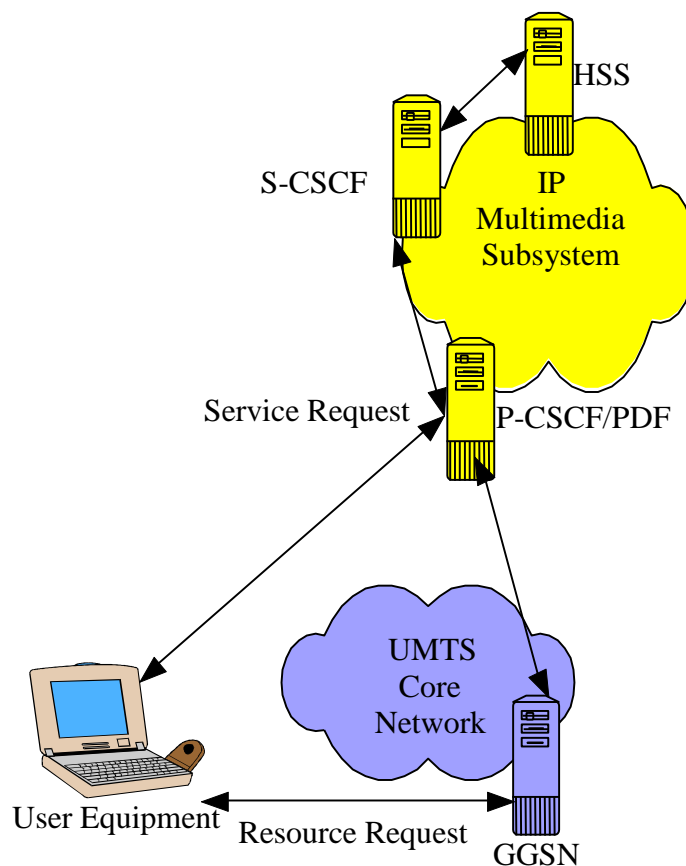

Figure 1: Policy Architecture in release 5

Although the PDF and P-CSCF are two separate logical entities, the release 5 3GPP specifications present the PDF as being an integral part of the P-CSCF. The consequence of this close coupling is that only the IP Multimedia Subsystem may authorize UMTS resources for their customers. The means for other services than IMS to authorize UMTS resources has not been standardised in Release 5.

6 Objectives

Opening the interface between the PDF and the P-CSCF may greatly simplify introduction of new services and enable operators to leverage their ownership of access networks by introducing opportunities for service-based control of the access for a whole range of services (potentially including third party services) in an operator controlled manner.

Decoupling of the PDF & P-CSCF could:

- Enable service based local policy control over IP bearer resources and SIP services to evolve separately.
- Facilitate future application of service based local policy control over IP bearer resources for non-SIP services (e.g., streaming services, etc.) that the operator will want to deploy.
- Improve network scalability/stability by allowing the decoupled functions to be scaled/upgraded independently according to network requirements.
- Encourage more flexibility in engineering and policy control of IP bearer resources. This means that policy control mechanisms for IP bearer resources related to SIP- & non-SIP-based

services, as well as their related IP bearer resources, can be controlled either together or separately.

- The interface should support quick development and implementation in new application functions to enable fast deployment. New applications do not require 3GPP standardisation.
- Facilitate future application of service based local policy control over IP bearer resources accessed using any IP-Connectivity Network (e.g., 3GPP2, WLAN).

In order to obtain all these benefits related to distributed policies, a generic protocol should be used allowing any service domain to provide session authorization to their customers in a particular IP Connectivity Network.

Figure 2 shows the IM Subsystem as well as other services, in relation to the UMTS Core Network. Decoupling of the PDF from the P-CSCF enables policy control to be applied for other services than SIP IMS services.

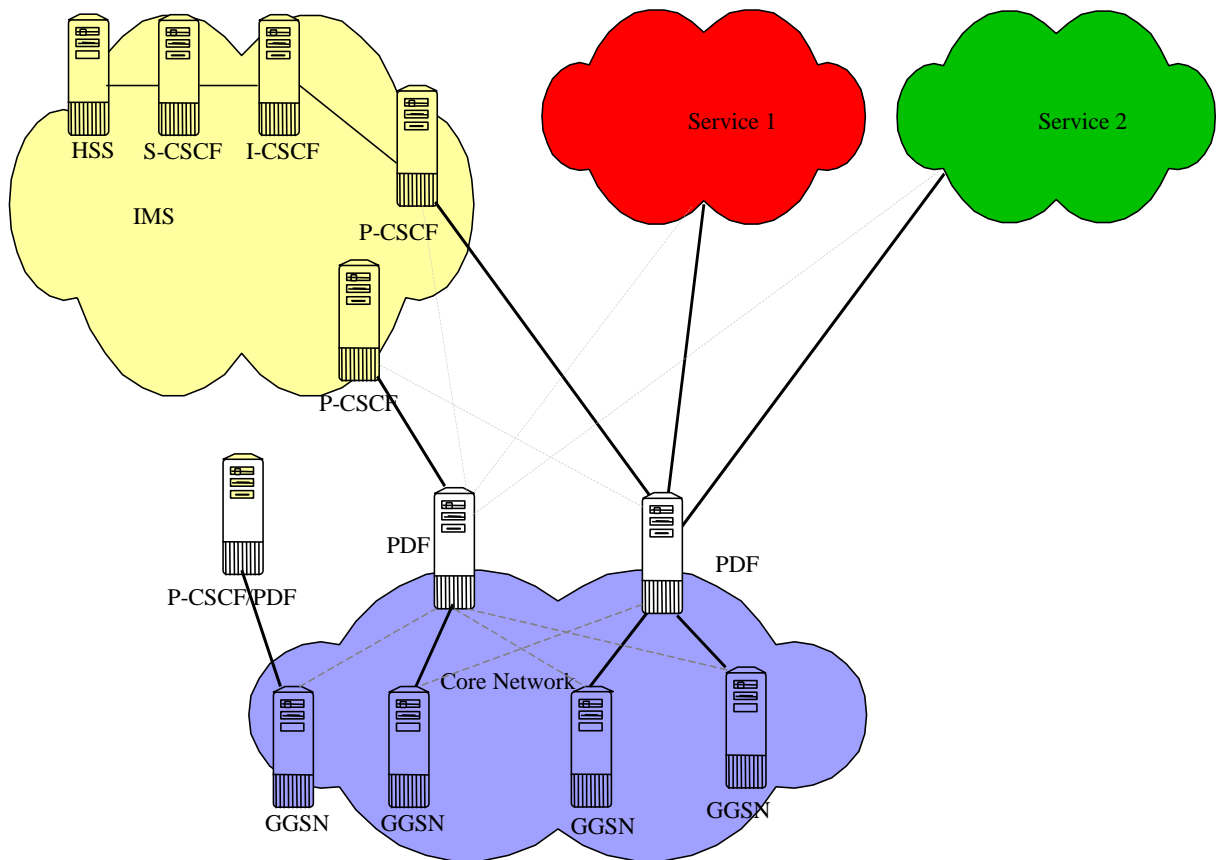

Figure 2: Policy applied to IMS and other services, also showing an integrated P-CSCF/PDF

The benefit of the service-based policy control for IMS and non IMS services will be investigated in this technical report. One example of non IMS service standardised by 3GPP is PSS based streaming services, for which rel6 policy control usage is evaluated. It is expected that other services (not necessarily standardised by 3GPP) may also use the evolved policy control in order to restrict the usage of the IP bearer resources (e.g. UMTS PS domain/GPRS domain resources).

7 Architecture

7.1 Introduction

There are three main elements to the rel6 policy control architecture:

- the Gateway between the Access IP-connectivity service and the IP multimedia network, (e.g., GGSN)
- the PDF
- the server in the operator's or service provider domain (e.g. P-CSCF for the IM Subsystem), or "Application Function".

7.2 Description of functional entities

7.2.1 Gateways

The Gateway GPRS Support Node (GGSN) is defined in TS 23.002 [2].

The procedures for information transfer between the GGSN and the PDF are defined in TS 23.207 [3] and TS 29.207 [4].

7.2.2 PDF

The Policy Decision Function (PDF) acts as a Policy Decision Point for service based local policy control. The PDF makes decisions about resources allocation requests.

7.2.3 Application Function

The Application Function is an element controlling applications that require the use of IP bearer resources (e.g. UMTS PS domain/GPRS domain resources). One example of an application function is the P-CSCF. The AF requests the PDF to apply restrictions on usage of the IP bearer resources.

The Application Function represents the application level intelligence for any service running over the IP bearer which needs service based policy control, and should not be confused with SIP Application Servers, OSA Application Server, or CAMEL IM-SSF defined in TS 23.228.

7.3 Relationship between functional entities

The following principles apply for the GGSN/PDF/Application Function relationships for the rel6 policy control architecture, in line with release 5:

There are multiple instances of the Application Functions, GGSNs and PDFs.

The Gateway and the associated PDFs exist within the same operator's network and are provisioned to know about each other (e.g., configured with a list of allowed names/addresses).

The AF and the PDF need not exist within the same operator's network. They may be provisioned to know about each other or one may discover the other and establish a secure relationship.

The Gateway, Application Function and PDF involved in establishing the session are not known a priori.

There are pre-defined trust relationships between the Gateway and the PDF.

Further, the following rules apply:

- One Gateway may get policy information from multiple PDFs. Different PDFs do not take decisions on the same resources of a single Gateway.
- A given PDF may give policy information to a number of Gateways
- One PDF shall be able to serve more than one Application Function
- For IMS services which PDF the Gateway needs to go to is identified by the authorization token
- The Gateway knows which PDFs are part of its network. This is for security reasons. The Gateway must have a list of valid PDFs to prevent a UE from tampering with the authorization token in order to redirect the Gateway to a fake PDF.
- A given Application Function may interact with a number of PDFs, although on a per-session basis, it shall interact with only a single PDF.

For IMS, where P-CSCF is the Application Function:

- The authorization token is generated by the PDF and contains its identifier (FQDN)
- A given PDF may interact with a number of P-CSCFs

For service based policy control, the AF does not interact with the Gateway directly; instead, it interacts with the PDF and the PDF acts on certain events as instructed by the AF. For certain events related to SBLP, the AF shall be able to give instructions to the PDF to act on its own, i.e. based on the service information currently available. The following events are subject to instructions from the AF:

- The authorization of the bearer establishment or modification.
- The revoke of authorization.
- The gate control.
- The forwarding of indications.

7.4 Functions with Policy Control

[Editor's Note: This section identifies the individual functions that are provided for policy control. Under each individual function, a description of the function and the distribution over the functional elements can be made. It can also indicate open questions for each function.]

7.4.1 Authorise QoS resources

7.4.1.1 Function description

There may be links between the AF and PDF policies to authorise the use of QoS resources. The PDF uses policy rules defined by the operator who owns the PDF to authorise the use of the IP bearer resources within the limits of what has been requested by the AF.

The AF provides the service determined decision information.

The PDF provides the final policy decision controlling the allocated QoS resources for the authorized session to the Gateway. The final policy decision is done according to operator policy rules defined in the PDF.

When the AF requests a token from the PDF, it indicates whether or not the PDF should contact the AF at UE resource reservation.

The Authorise QoS resources function can be invoked between PDF and AF at session establishment and/or at bearer establishment. The PDF provides a successful result to the authorization request from the AF only if the session characteristics are consistent with the policy rules defined in the PDF.

The UE decides whether to aggregate or separate flows for media. The total QoS authorised may depend on which flows the UE decides to multiplex. Depending on the flows and the application, there may be some multiplexing gain (e.g. it may be that some flows never transmit at the same time).

As the AF can request to be contacted at UE resource reservation, it can interact with the PDF so that the PDF enforces downgraded bandwidth usage if the UE has asked for more bandwidth than the AF allows.

Further, the AF may provide information to the PDF in order for the PDF to authorise aggregate of for media.

In the case the AF does not request to be contacted at UE resource reservation, and that no additional information is available at the PDF, the PDF authorisation will be based on information previously provided by the AF and the addition of bandwidth for the media proposed by the UE.

For some services, the authorisation decision may be time dependent (e.g. a different authorisation is applicable at a different time). Further, different services may make the authorisation decision for the media at the AF at the time the media is identified, and others may make this authorisation decision at the AF at the time the bearer is established. If a time dependent decision at the AF needs to be made at bearer establishment, the AF shall request the PDF to contact the AF at UE resource reservation.

After successful session establishment, the Authorise QoS resources function can be invoked again between PDF and AF at session modification and/or at bearer modification. The PDF shall update the policy decision based on the information received from the AF. Under certain conditions, such as removal of media or modification of media parameters, the PDF enforcing the updated policy decision shall invoke procedures as described in 3GPP TS 29.207 [4].

7.4.1.2 Gq Data exchange

a) Description of session QoS information: the AF may provide one or more of the following information when describing the session. The set of information that needs to be sent in different cases needs to be further determined.

- Application identifier: identifies the particular service that the session belongs to. This information may be used by the PDF to differentiate QoS for different application services. For example application identifier may be used as additional information together with the indication of the type of service information when QoS class for the bearer authorisation in Gq interface is decided. The application identifier may be used also to complete the QoS authorisation with application specific default settings in the PDF if the AF does not provide all or any of the following information.
- Information defining the media
 - Medium Id (to uniquely identify the medium in the session)
 - Information defining the flows of the session.
 - direction (bi-directional, uplink / downlink)
 - 5-tuple (source/destination address and port number, protocol Id)
 - indication of the maximum and/or mean bandwidth required
 - An indication of the requested type of service handling per service-flow, e.g., conversational voice or video, streaming voice or video

b) Definition of whether to contact the AF at resource reservation or not.

c) Install Gating Rules: Definition of whether gating control is used or not. If gating control is not used, the PDF keeps the gates always open. It is FFS whether this applies per media component, per session or per application.

The PDF provides a successful result to the authorization request only if the session characteristics are consistent with the policy rules defined in the PDF.

7.4.2 Exchange of information for charging correlation

7.4.2.1 Function description

IMS charging information is available from the P-CSCF for the PDF which is required to transfer it to the IP-Connectivity Network Gateway.

IP-Connectivity Network charging info available in the PDF is required to be transferred to the AF.

7.4.2.2 Gq Data exchange

Transfer of an IP-CAN charging identifier, e.g. GCID

Transfer of AF charging identifier, e.g. ICID

7.4.3 Enable media

7.4.3.1 Function description

The AF determines when media is to be enabled to pass through the access network.

The PDF opens the corresponding gate in the Gateway when instructed by the AF. The AF shall be able to instruct the PDF to either react on a separate message to enable the media or to open the gate as part of the authorization of the bearer establishment for the media .

7.4.3.2 Gq Data exchange

AF instruction to open gate

PDF indicates the result of the operation.

It is FFS whether it is also possible that the PDF decides not to open the gate, with an indication of the reason why.

7.4.4 Disable media

7.4.4.1 Function description

The AF determines when media is to be disabled from passing through the access network.

The PDF closes the corresponding gate in the Gateway when ordered from the AF.

7.4.4.2 Gq Data exchange

AF instruction to close gate

PDF indicates the result of the operation.

It is FFS whether it is also possible that the PDF decides not to close the gate, with an indication of the reason why.

7.4.5 Revoke authorisation

7.4.5.1 Function description

The AF determines when a previous authorisation decision is no longer approved, and orders the removal of the previously authorised resources.

The PDF revokes the QoS resources when instructed by the AF. This results in removing the allocated resources in the Gateway.

The AF can revoke the authorisation token.

The AF requests all authorisations related to this authorisation token, and all gates associated with the authorisations to be removed. The authorisation token will no longer be accepted from the UE. Any PDP contexts with binding information containing this authorisation token will be removed.

It is up to stage 3 whether a combined request to immediately close gates, and revoke the authorisation token (which may involve a time delay) is supported.

Note: If the session changes at the Application Function, the AF may update the service information to the PDF. The PDF may revoke authorisations in the gateway (i.e. GGSN for GPRS) carrying media which are removed where the UE does not modify the bearer to remove such media.

7.4.5.2 Gq Data exchange

For the revoke request, the AF will identify the authorisation token to be revoked.

There is no additional data required for the revoke request acknowledgement.

7.4.6 Indicate bearer release/failure

7.4.6.1 Function description

Information available at the PDF on the bearer resource release or failure is passed through to the AF. The AF shall be able to instruct the PDF whether or not to pass such information.

7.4.6.2 Gq Data exchange

Indication from the PDF that the IP-CAN can no longer fulfil QoS commitments

7.4.7 Confirm bearer reservation

7.4.7.1 Function description

The PDF forwards bearer reservation indications to the AF which confirms whether the previous resource authorisation should still be applicable. AF shall be able to instruct the PDF whether or not to forward such indications.

7.4.7.2 Gq Data exchange

Indication that the bearer resources have been established.

It is FFS what data this contains.

It is FFS whether this is done only when all media related to the authorisation are established, or earlier indications are also possible.

7.5 Description of interfaces

The Rel6 policy control makes usage of:

- The interface between the Gateway and the PDF (Go interface) for service based local policy control.

The Go interface ensures that the PDF policy decisions are applied at the Gateway over the IP-Connectivity Network domain and over the Gi interface.

- The interface between the Application Function (e.g. P-CSCF for the IM Subsystem) and the PDF (Gq interface) for service-based policy control.

The Gq interface ensures that the PDF policy decisions are applied for the service requesting access to IP bearer resources.

Gq interface may be intra- or inter-domain. Gq shall support relevant protection mechanisms for an inter-operator or third party interface. The exact mechanisms required are FFS.

7.6 Binding mechanism handling

This refers to the binding between any session information that may be provided by the Application Function, and the authorisation of QoS resources usage for that application, by the PDF. The binding mechanism for service based policy control uses an authorisation token. The authorization token is passed among the PDF, AF and Gateway and is linked with session bearer information. Since PDFs, AFs, and Gateways, may exist in many to many relationships, the specific Gateway and PDF and the specific PDF and AF supporting a particular session must be known to each other. The AF may be provisioned to know about the PDF or the AF and PDF may discover each other by other means.

In response to a session bearer authorization request from the AF, an authorization token is generated by the PDF and is passed back to the AF. The following are possible:

1. The PDF authorizes QoS resources usage for that application for a particular session and user. The authorization token is only valid for the duration of the session for the specific user.
2. The AF requests multiple authorization tokens. The PDF provides the requested number of authorization tokens. Each of these tokens may later be allocated to a session, and then used for subsequent QoS resource usage authorization procedures for the duration of the session for the specific user.

This authorization token is used in the initial communications between the PDF and the Gateway to identify bearers related to this session. If the authorization token is not yet related to a session bearer authorization request it is also used in the initial communications between the PDF and the AF. It contains the address of the PDF that has assigned the authorization token. The AF later passes this authorization token to the UE which then passes it when requesting a bearer from the Gateway.

The message flows in Section 8.3 'Authorisation of QoS resources' show an example of this binding case.

8 Information flows

For distributed policies, a generic protocol should be defined allowing any Application Function to request session authorization for their customers in a particular access network. A number of different scenarios are described here which all have the common point of requiring a dynamic policy decision.

8.1 General operation of Gq interface

The Gateway resources are used by an Application Function. The interface between the Application Function and the PDF is used for service based policy control. The PDF exchanges requests/responses and indications with the Application Function.

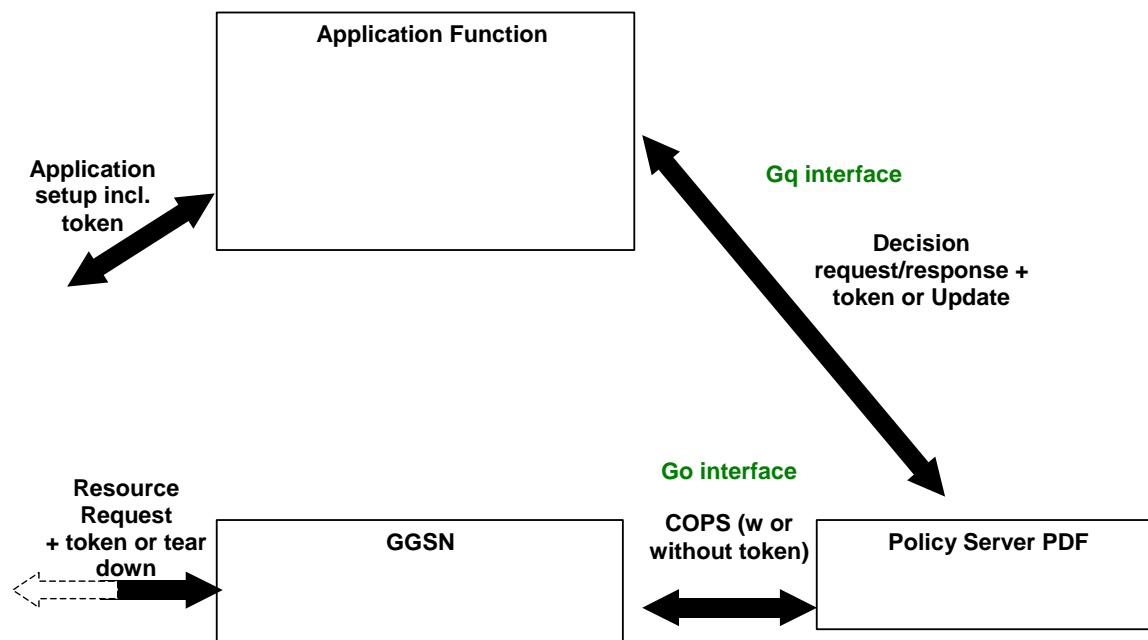

8.2 Example usage with IMS

8.2.1 IMS Session setup

The following picture shows a high-level view of release 5 information flows over the Gm and Go interface, during session setup, as well as information exchange over the Gq interface between P-CSCF and PDF.

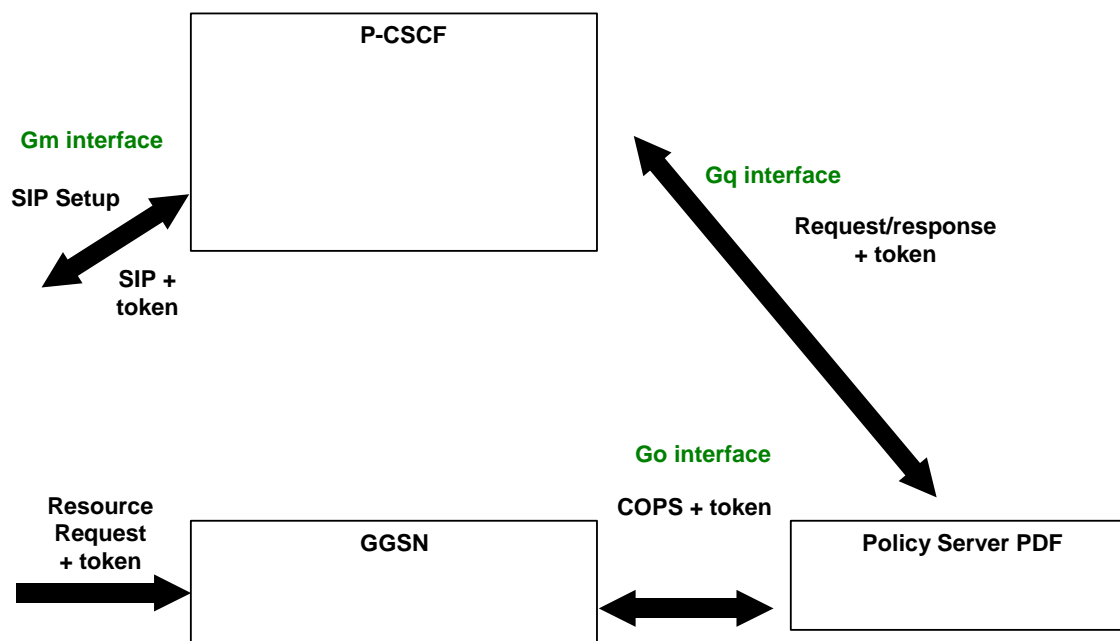

Over the Gm interface, SIP session control is exchanged between UE and P-CSCF.

Over the Gq interface, information is exchanged between the Application Function (P-CSCF) and the PDF, for policy decisions.

At the Gateway, resources are requested for the related session. Policy is enforced at the IP-Connectivity Network Gateway following information exchanged with the PDF over the Go interface.

The authorisation token is exchanged over those interfaces as required.

8.2.2 IMS Session teardown

The following picture shows a high-level view of release 5 messaging over the Gm and Go interface, during session teardown, as well as information exchange over the Gq interface between P-CSCF and PDF.

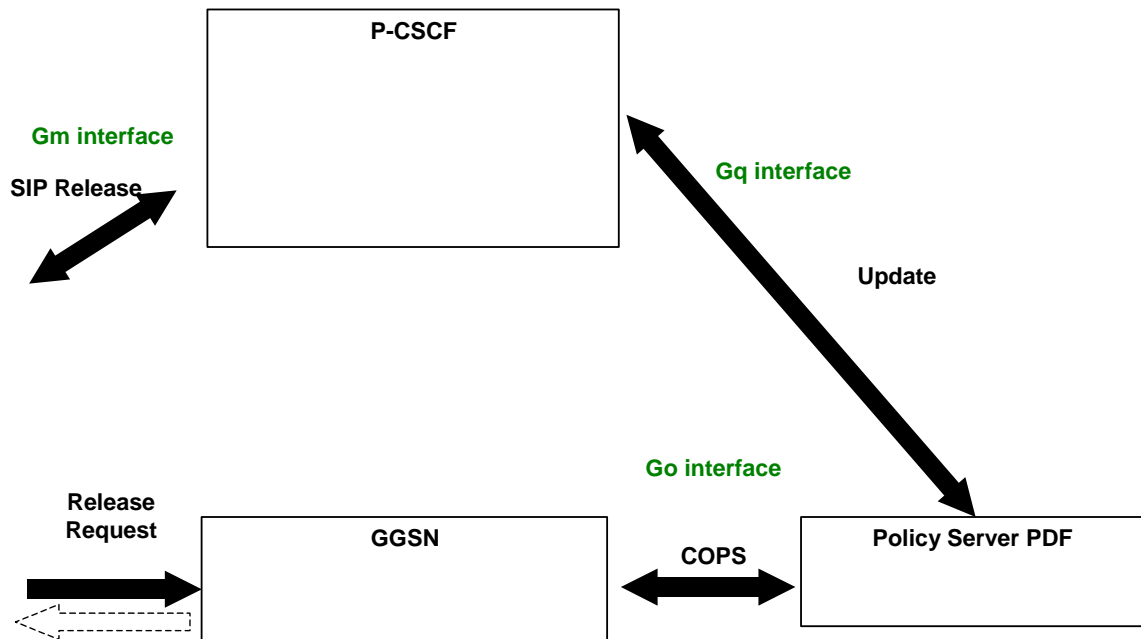

Over the Gm interface, SIP session control is exchanged between UE and P-CSCF.

Over the Gq interface, information is exchanged between the Application Function (P-CSCF) and the PDF, for policy decisions.

At the Gateway, resources are released for the related session. Update information is exchanged between the Gateway and the PDF over the Go interface.

8.3 Authorisation of session QoS resources

This is the initial interaction between PDF and AF.

When the AF requests the authorization token from the PDF, it indicates whether or not the PDF should contact the AF at UE resource reservation. The PDF generation of the authorization token is shown in the message flow “Authorisation of service, session establishment”. In the case where the AF provides session QoS information, the PDF returns a success indication with an authorization token when the session characteristics are consistent with the operator policy rules defined in the PDF. In the case where the AF does not provide session QoS information, the PDF may return an authorization token to be used in a subsequent authorisation procedure.

The AF provides information about whether or not the PDF should contact the AF when the QoS is modified by the UE, for example if there is a change in the allocation of media to the authorized resources.

The PDF can only provide this modification information to the AF if it receives corresponding information from the Go interface.

8.3.1 Authorisation of QoS resources, session establishment

The following message flow shows the authorisation of the QoS resources at session establishment. This step is necessary for the AF to request the generation of any authorization token by the PDF.

For a particular user and session, the PDF generates one authorization token which is valid for the related session and user.

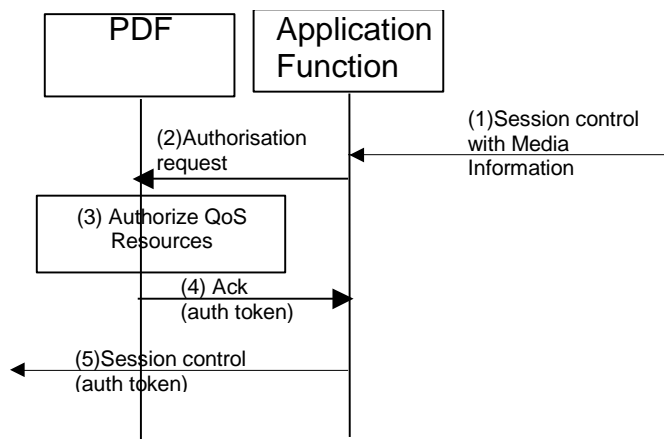

Figure 3: Authorize QoS resources, session establishment

- 1) A trigger is received at the AF, e.g. a session Control message containing media information is received by the Application Function.
- 2) The Application Function sends a request for authorization token and optionally session QoS information to the PDF. Some services may require further interaction between the AF and the PDF to provide the full session information, e.g. for IMS session establishment (mobile terminated).
- 3) If the PDF received the session QoS information and if the session characteristics are consistent with the policy rules defined in the PDF, the PDF authorizes the required QoS resources for the session and installs the IP bearer level policy in its internal database based on information from the Application Function. If the session QoS information was not received in Step 2 above, the QoS authorisation is deferred.

It is FFS how the PDF shall respond if the session characteristics are not consistent with the policy rules defined in the PDF. Possible options to consider include:

- a. PDF rejects the authorisation request with an indication of what could have been accepted.
 - b. PDF authorizes lower QoS resources with an indication of what has been authorised. Other responses from the PDF may also be considered.
- 4) The PDF reports successful or deferred QoS authorisation of the session, to the Application Function. The requested Authorisation Token shall be included.
 - 5) Upon successful or deferred authorization of the session, session control messaging continues, with the supplied Authorisation Token being passed on the UE.

It is also possible that the AF may initiate a request for multiple authorization tokens to use for future sessions, in which case the PDF can generate multiple authorization tokens. When the AF receives

multiple authorization tokens from the PDF, it may allocate these to sessions without re-contacting the PDF.

8.3.2 Authorisation of QoS resources, bearer establishment, and exchange of information for charging correlation

At bearer establishment, the PDF can contact the AF. This may be done in the case that the previous interaction at session establishment requested this, or when the previous interaction did not include QoS information for authorisation at that time. This further step is used for confirmation of reservation as required by the AF.

The following message flow shows the authorisation of the QoS resources at bearer establishment, and the exchange of information for charging correlation.

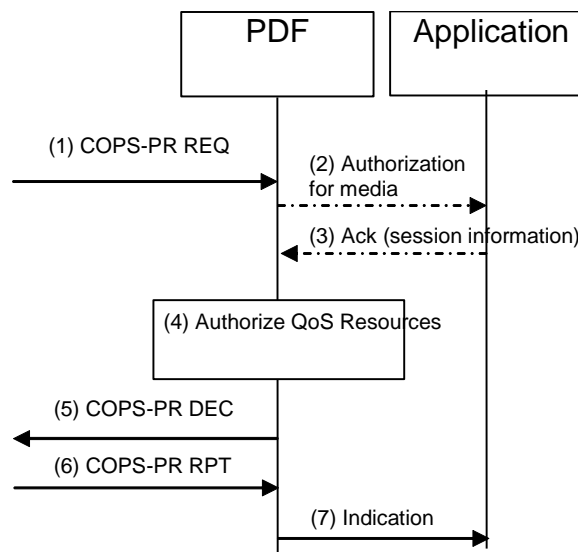

Figure 4: Authorize QoS resources, bearer establishment, and exchange of information for charging correlation

- 1) A COPS-PR REQ is received over the Go interface at the PDF.
- 2) A PDF generated authorization token enables the PDF to identify the authorisation status information. If the previous PDF interaction with that AF had requested this, or if the previous interaction with the AF did not include session QoS information, the PDF sends an authorisation message to that Application Function.
- 3) The AF sends the session QoS information to the PDF.
- 4) If the session characteristics are consistent with the policy rules defined in the PDF, the PDF authorizes the required QoS resources for the session and installs the IP bearer level policy in its internal database. This is based on session QoS information from the AF in step 3 or during previous PDF interaction with that AF.

It is FFS how the PDF shall respond if the session characteristics are not consistent with the policy rules defined in the PDF. Possible options to consider include:

- a. PDF rejects the authorisation request with an indication of what could have been accepted.
 - b. PDF authorizes lower QoS resources with an indication of what has been authorized.
- Other responses from the PDF may also be considered.

- 5) The PDF sends further Go messaging.
- 6) A COPS-PR RPT is received over the Go interface at the PDF containing the IP-Connectivity Network charging information.

- 7) The PDF shall send an indication for the successful bearer establishment, which contains the received IP-Connectivity Network charging information, to the AF.

8.3.3 Example of authorisation of QoS resources and exchange of information for charging correlation, P-CSCF is Application Function

One example of usage of the authorisation message flow above is at IMS session setup using GPRS. This scenario is shown below:

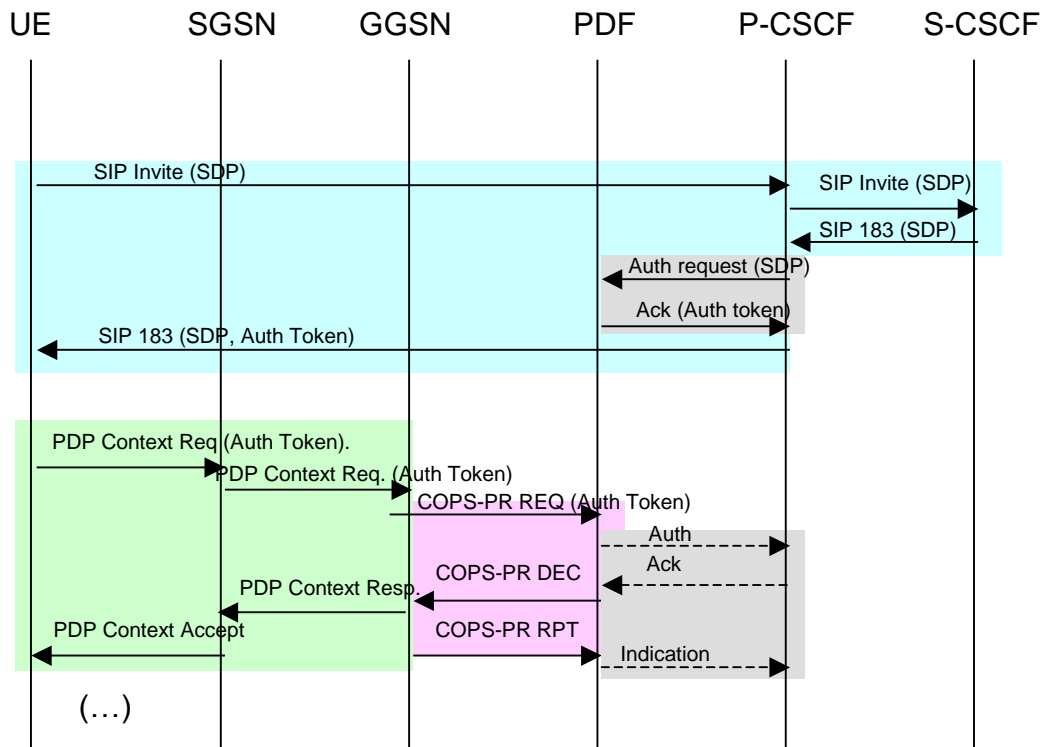

Figure 5: Example Information flow for IMS session set-up

The P-CSCF sends an authorisation request message to the PDF to request an authorisation token. The message may include SDP information. All possible interactions between P-CSCF and PDF at this stage are not shown in this call flow. The P-CSCF may provide sufficient information to enable the PDF to make authorization decisions.

The PDF uses the session QoS information received from the P-CSCF in order to authorize the necessary QoS resources.

An authorisation token is generated by the PDF. The authorisation token is a globally unique value. This authorisation token includes the PDF identifier. The PDF identifier ensures that the GGSN knows which PDF to contact for Go interface flows.

The PDF sends an acknowledgement message to the P-CSCF containing the Authorisation Token.

If the P-CSCF had requested to be instructed at resources setup, the PDF further interacts with the P-CSCF on bearer establishment. The P-CSCF makes an IMS decision on the authorisation and sends session QoS information to the PDF. The PDF makes an authorisation decision which is communicated to the GGSN. The successful installation of the decision is reported to the P-CSCF together with the GPRS charging information received.

8.4 Approval of QoS commit

The PDF uses information received from the application function, in order to enable the authorised QoS resources.

The PDF controls the gate(s) but opens the gate(s) only if it gets an indication from the Application Function.

Depending on operator configuration the Application Function may also enable the authorised QoS resources during the authorization procedure.

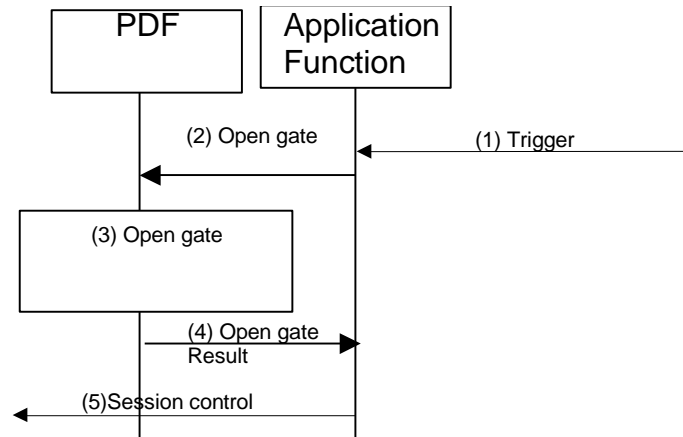

Figure 6: Approval of QoS commit

- 1) A trigger is received at the AF e.g. a Session Control message is received by the Application Function, or an internal action at the AF triggers the need to enable the media for the application.
- 2) The Application Function sends an open gate indication to the PDF.
- 3) The PDF enables use of authorised QoS resources. Response of the operation in the GGSN is received by the PDF.
- 4) The PDF responds with the result of the operation to the Application Function.
- 5) Session control continues.

8.4.1 Example of approval of QoS Commit, P-CSCF is Application Function

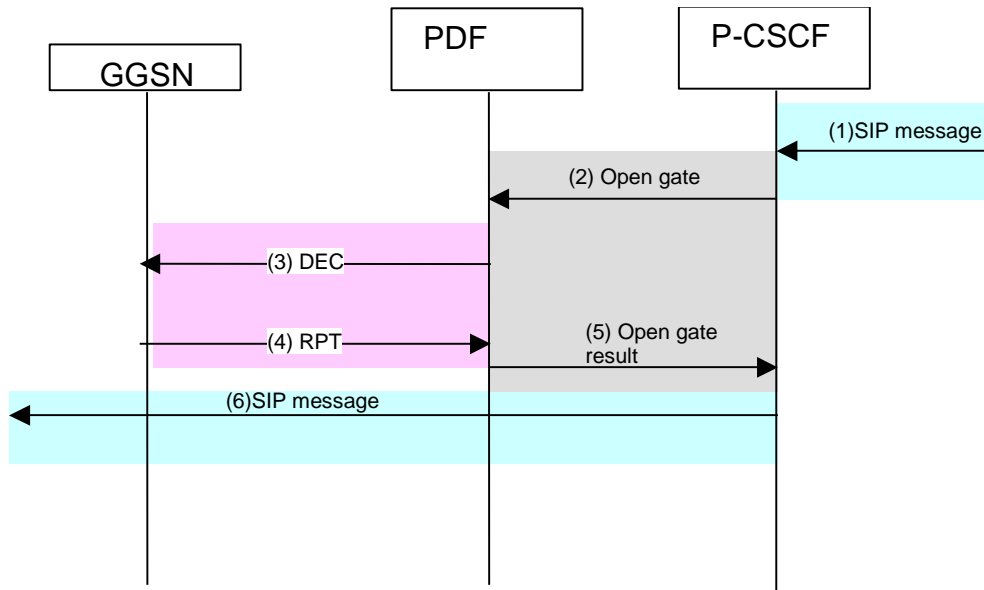

Figure 7: Example IMS flow of approval of QoS Commit

- 1) The P-CSCF receives a SIP message with an SDP answer.
- 2) The P-CSCF sends a message to the PDF to indicate the opening of the gate.
- 3) The PDF shall send a COPS DEC message to the Gateway to open the 'gate' e.g., enable the use of the authorised QoS resources.
- 4) The Gateway receives the COPS DEC message and opens the 'gate' e.g., enables the use of the authorised QoS resources, and sends a COPS RPT message back to the PDF.
- 5) The PDF informs the P-CSCF of the result of the gate operation.
- 6) The P-CSCF forwards the SIP message to the UE for the originating side and for the terminating side, to the terminating S-CSCF.

8.5 Authorisation of modification of network resources

This procedure is used when a modification of network resources happens which is outside of the limits that were authorized at network resource activation (or last modification).

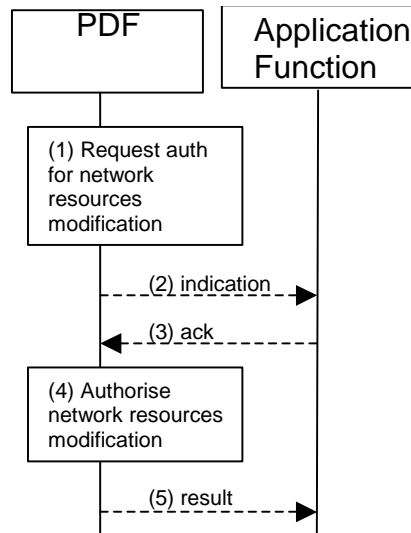

Figure 8: Authorisation of network resources modification

- 1) The PDF is requested to authorise a network resources modification
- 2) The PDF may give this bearer modification indication to the Application Function. This may be the case if this was requested from the AF at initial authorisation, and if PDF requires more information from the AF before authorising the network resources modification.
- 3) The AF shall send information for authorization of this modification.
- 4) The PDF authorises the network resources modification
- 5) In case the PDF had contacted the AF in 2) then the successful installation of the decision is reported to the AF

8.5.1 Authorisation of network resources modification, PDP context modification to IMS

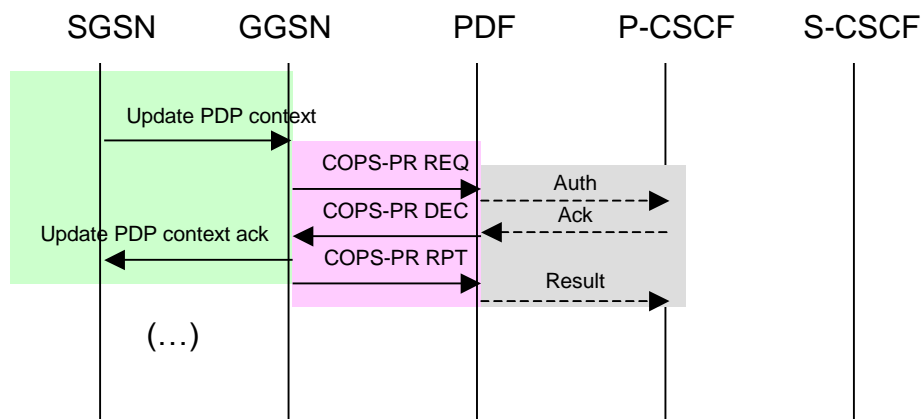

Figure 9: Example of information flow for authorisation of PDP context modification towards IMS using GPRS

The PDF is requested to authorize the modification of the network resources previously authorized.

This is done via the Go interface with the COPS-PR REQ message.

The PDF may authorize the modification request at this point. If required for the authorization to proceed, the PDF may send an authorization request to the P-CSCF. In this case, the P-CSCF shall send an answer with information for authorization of this modification and the PDF shall report the result to the P-CSCF.

8.6 Indication of network resources events

This procedure is used when an event, e.g. a loss of coverage, happens in network resources. It does not require the PDF to perform an authorisation for this modification.

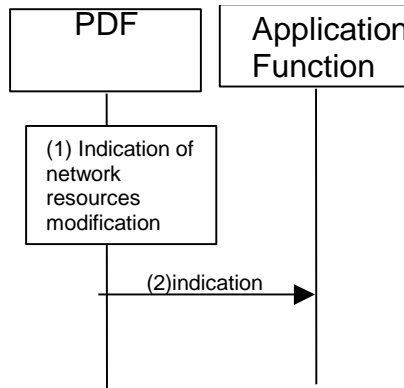

Figure 10: Indication of network resources modification

- 1) The PDF is instructed of a network resources modification
- 2) If this modification matches the criteria for which that the AF had requested to be informed, the PDF shall give this bearer modification indication to the Application Function

8.6.1 Indication of network resources modification, PDP context modification to IMS

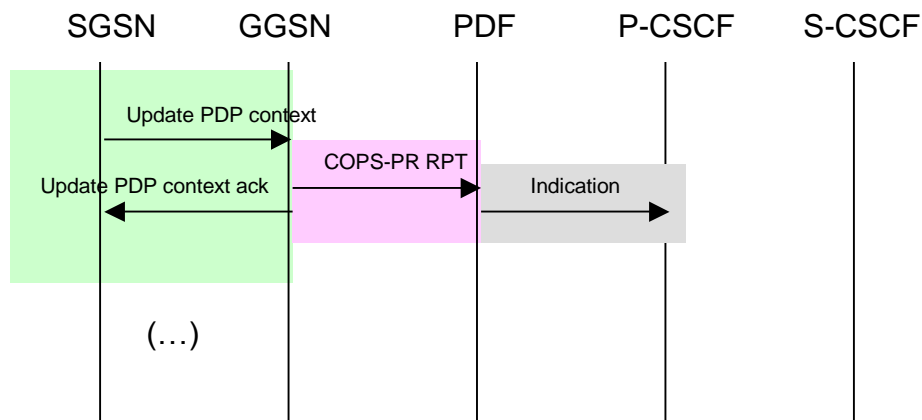

Figure 11: Example of information flow for indication of PDP context modification towards IMS using GPRS

The PDF is informed about the modification of the network resources previously authorized.

This is done via the Go interface with the COPS-PR RPT message.

In this case, the PDF had received an indication from the P-CSCF to report any modification, therefore the PDF sends an indication to the P-CSCF.

8.7 Revoke Authorization for the session

8.7.1 Revoke Authorization for the session, Application Function initiated

This procedure is used e.g. upon session release. The AF may separately request immediate disabling of the media for this session using the disable media procedure. This capability may also be available as an option with the revoke authorisation token request. .

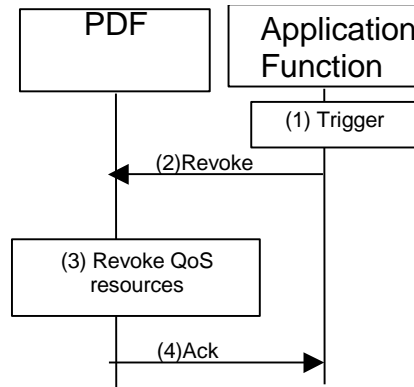

Figure 12: Revoke Session Authorization, Application Function initiated

- 1) A trigger is received at the AF e.g. a session control message exchange, or an internal action at the AF triggers the need to revoke the authorization, or the AF received an indication of network resources removal and decides to revoke the authorization
- 2) The Application Function sends a message to the PDF to revoke the authorisation token.
- 3) The PDF when it is informed of the revocation, revokes the related QoS resources which had been previously authorised. The PDF also records that the associated token value is no longer used.
- 4) The PDF indicates the successful execution of the revoke indication.

8.7.2 Revoke Authorization for the session, PDF initiated

In this scenario the PDF initiates the release of the session. This may only happen in case the AF allows the PDF to revoke the service. If the PDF is allowed to revoke the service, this may happen for a number of reasons e.g. there is some time restriction. The PDF triggers the procedures in the AF to revoke the authorisation token.

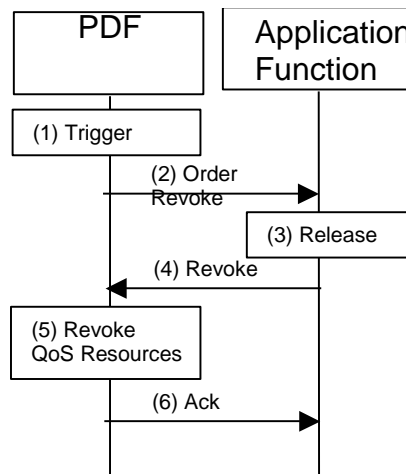

Figure 13: Revoke Session Authorization, PDF initiated

- 1) The PDF decides the authorisation token and all related authorizations must be revoked
- 2) The PDF orders the AF to revoke the authorisation token
- 3) The AF may initiate session signaling related to the media termination.
- 4) The AF requests the PDF to initiate the revoke procedures for the authorisation token
- 5) The PDF revokes the related QoS resources which had been previously authorised. The PDF also records that the associated token value is no longer used.
- 6) The PDF indicates the revoke of the authorisation to the AF.

8.7.3 Revoke for IMS Session release, P-CSCF is Application Function, P-CSCF initiated

One example of usage of the revocation message flow above is at IMS session teardown. One IMS teardown possible scenario using the revocation message flow is shown below.

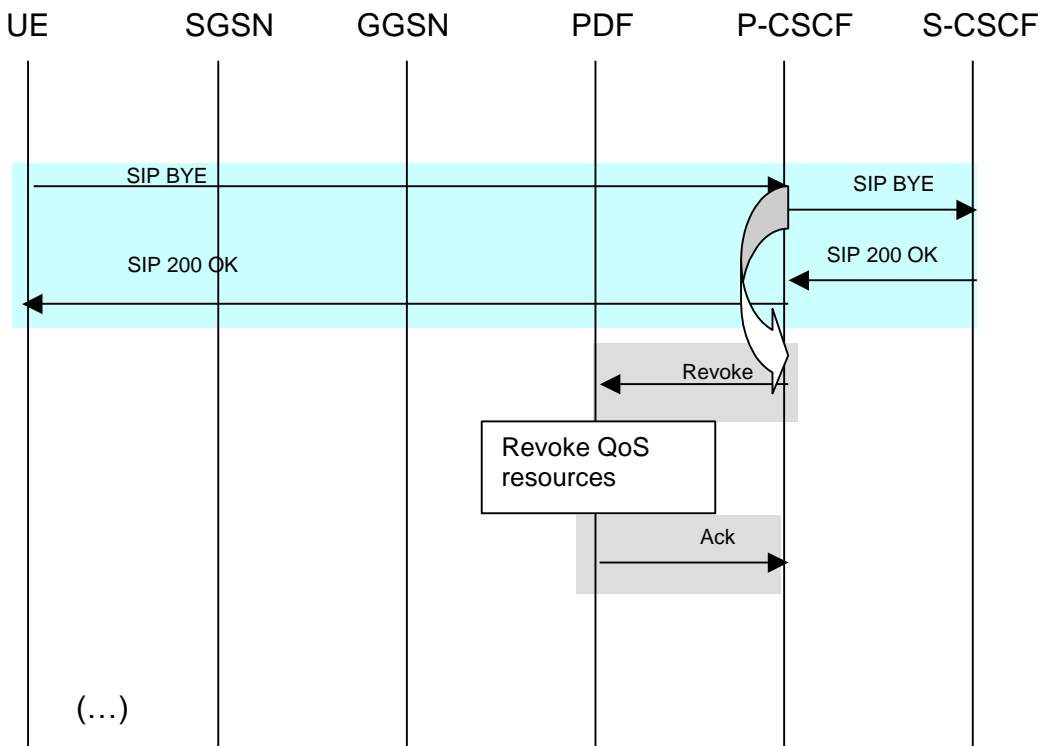

Figure 14: Example of information flow for IMS session release using GPRS, P-CSCF initiated

In this scenario, upon receiving SIP BYE the P-CSCF sends a message to the PDF to revoke the authorisation token. This indicates to the PDF that the token value needs to be released and all associated authorisations are no longer valid. The PDF then revokes the related QoS resources.

8.8 Update Authorization for the session

If the session changes at the Application Function, an update of the previous authorisation may be given to the PDF. This is shown in the message flow below:

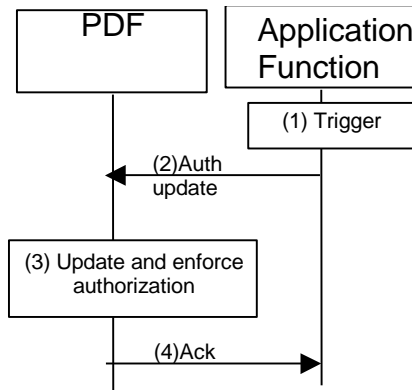

Figure 15: Update Authorisation for the session

- 1) At the AF, e.g. through modification of the session at session control level, there is a need to give updated session QoS information to the PDF.
- 2) The AF gives the updated session QoS information to the PDF
- 3) The PDF updates the authorisation for the session. Under certain conditions the PDF enforces the updated authorisation via the appropriate Go procedures, e.g. via the revoke GPRS and IP resources procedure.
- 4) The PDF sends an acknowledgement to the AF

8.9 Removal of QoS commit

The "Removal of QoS commit" procedure is used e.g. when media of a session is put on hold. (e.g. in case of a media re-negotiation or call hold).

The PDF uses information received from the Application Function, at the session control level, in order to disable the authorised QoS resources. The PDF controls the gate(s) but closes the gate(s) only if it gets an indication from the Application Function. Depending on operator configuration the Application Function may also disable the authorised QoS resources during the revoke authorization procedure.

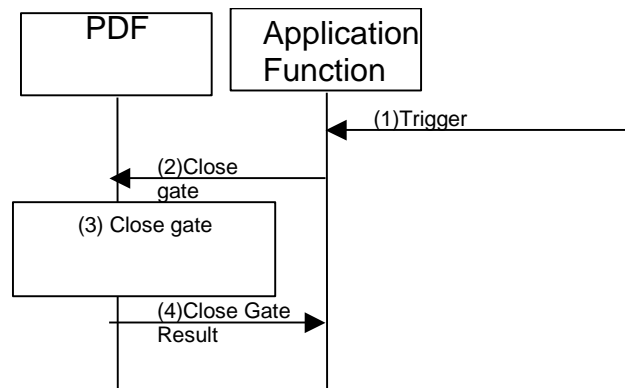

Figure 16: Removal of QoS commit

- 1) A trigger is received at the AF e.g. a session control message exchange, or an internal action at the AF triggers the need to stop the media for the application.
- 2) The Application Function sends a close gate indication to the PDF.
- 3) The PDF takes the appropriate actions to close the gate. Result of the operation in the GGSN is received by the PDF.

- 4) The PDF reports the result of the close gate operation.

8.9.1 Removal of QoS Commit, P-CSCF is Application Function

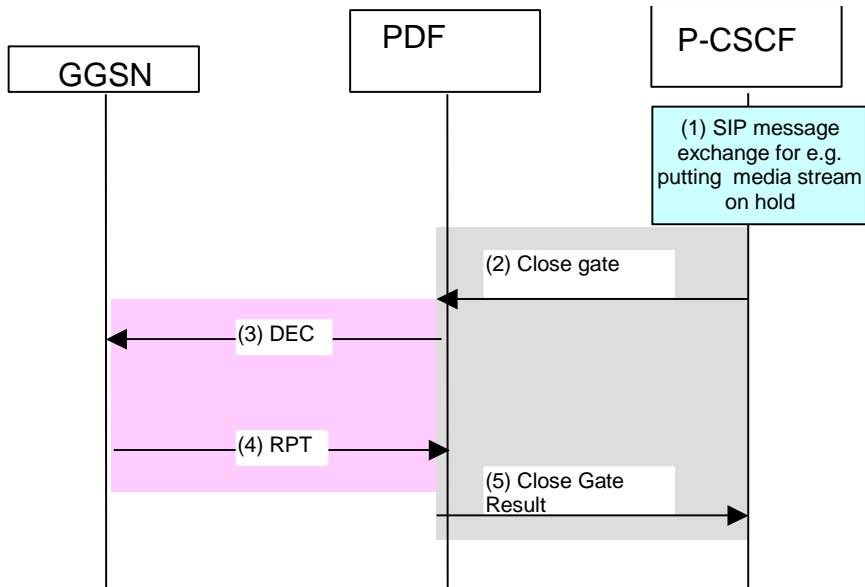

Figure 17: Example of IMS flow for Removal of QoS commit

- 1) SIP message exchanges for e.g., putting media on hold are carried out.
- 2) The P-CSCF sends a message to the PDF to indicate the closing of the gate.
- 3) The PDF shall send a COPS DEC message to the Gateway to close the 'gate'.
- 4) The Gateway receives the COPS DEC message, closes the gate, and sends a COPS RPT message back to the PDF.
- 5) The PDF informs the P-CSCF of the result of the close gate operation.

8.10 Indication of network resources removal

This procedure is used e.g. upon GGSN deletion of PDP context. It shall trigger the PDF to forward this indication to the Application Function if the AF had requested to be informed.

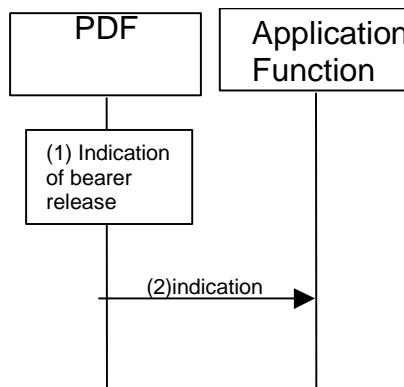

Figure 18: Indication of bearer removal

- 1) The PDF is instructed of a network resources removal
- 2) If this indication matches the criteria for which the AF had requested to be informed the PDF shall give this bearer removal indication to the Application Function.

Note: Under certain conditions the PDF may revoke the whole authorization.

8.10.1 Indication of network resources removal, PDP context release to IMS

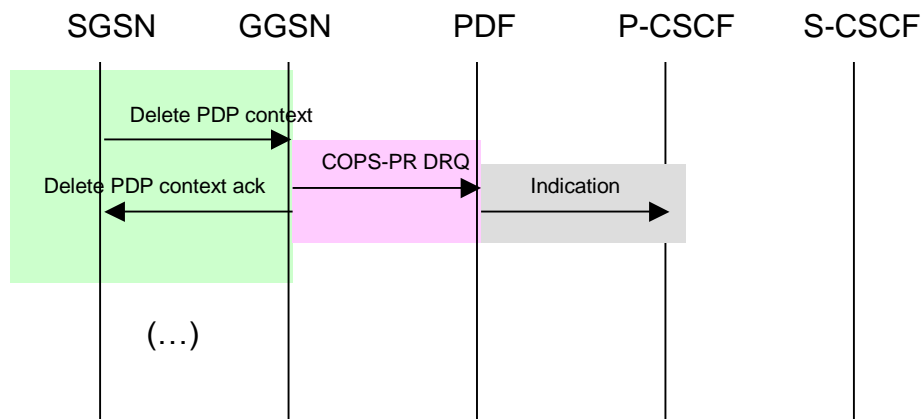

Figure 19: Example of information flow for indication of PDP context release towards IMS

The PDF is informed about the deletion of the network resources previously authorized.

This is done via the Go interface with the COPS-PR DRQ message.

The PDF shall send an indication to the P-CSCF in case the P-CSCF had requested to be informed.

Note: Under certain conditions the PDF may revoke the authorization for the session.

9 Function Requirements

This section identifies the requirements for support of the architecture:

General Requirements

1. Regardless of how the architecture evolves, the release 5 solution with a Go interface between the PDF/P-CSCF and GGSN must be retained for backwards compatibility. Development of the Go protocol is out of scope of this TR.
2. The Gq protocol should be service agnostic.
3. The Gq protocol should be IP-Connectivity Network independent.
4. The AF shall be able to give instructions to the PDF on how to act on certain events related to SBLP.

Service Requirements

1. The Gq reference point shall be able to work on a higher granularity of description information exchange than the Go reference point. The AF sends service description information while the PDF converts this information to the next lower level, i.e. media component (in case SDP is used by the service) or IP flow description information.

2. There are many different services that can be provided over the IP bearer resources (e.g. UMTS PS domain/GPRS domain resources). The general requirements for policy control, which should be common to most services requiring SBLP, include the following:

The Application Function needs to be able to:

- a. Request the PDF to apply restrictions on usage of the IP bearer resources of the access network (e.g. UMTS PS domain/GPRS domain resources)
- b. Provide service determined policy information
- c. Indicate characteristics/needs of service
- d. Exchange charging correlation information to the IP bearer resources network.
- e. Control usage of authorised IP bearer resources (gating)
- f. Be informed of particular IP bearer resources network situations

10 Example of rel6 policy control usage with a PSS application and GPRS IP-Connectivity Network

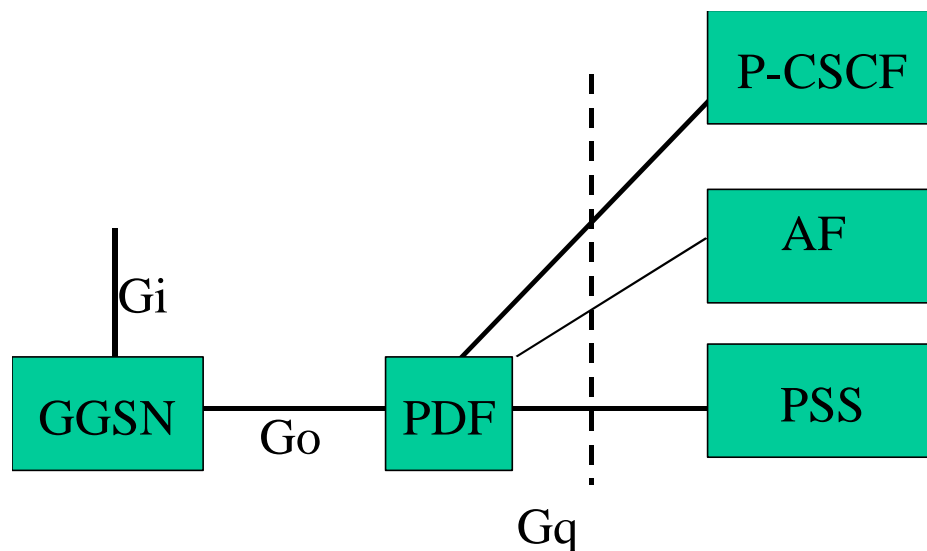

An RTSP session to the PSS server constitutes the signalling, with a separate bearer set up for the media which may utilise RTP/RTCP but which may be some other protocol, dependent on the source and the media type.

When the UE makes a session request in the PS domain (i.e. a PDP context request) the GGSN requests authorisation from the PDF via the Go interface, using the authorisation token that the UE included in the PDP context request.

The PDF informs the GGSN of the agreed session parameters and the GGSN will allow, decline or negotiate down the request after cross checking this with the parameters requested by the UE.

The scenario described here for PSS services would require the PSS server to support the Gq interface, and the UE to support passing the authorisation token, which are mechanisms not supported in the existing PSS application. Existing PSS services are defined in TS 26.233 and do not use the PDF. To support SBLP control which uses the PDF, PSS servers would need to support the Gq interface in addition to the requirements from TS 26.233.

Existing PSS services (not using additional -rel6 functionality as described in this TR) can be created (including support for 3GPP users) to access streaming services including services outside of the operators domain (currently available in the Internet today). These services do not control the access of the IP bearer resources via the PDF.

Application of policies beyond an operator domain is subject to roaming agreements. If we use the PDF for PSS, a PSS server outside of the operator's domain, requires either access to the PDF of the operator's domain, or access to an AF in that domain. Hence user experience in the roaming scenario can vary if proper roaming agreements and SLAs are not in place.

- It is necessary to avoid widely different policies within different operators, as this will likely cause service disruption towards user experience due to frequent changes in the service-QoS mapping table in the UE when roaming.

- Applying policy requires an added authorization mechanism (compared to when always allowing any PSS, where this authorization mechanism does not happen).

-SDP usage for a streaming service may not be available to the PSS server, in such cases using SBLP is only possible when there is some other means to provide the PSS server with information about the media.

The message flows for PSS system are shown below. The message flows assume that GGSN, PSS & PDF are all aware of each other's existence and within an operator's domain. The session release flows shown below show a UE initiated session release.

It should also be noted that the PSS server in the current PSS service scenarios does not initiate session release towards the terminals, sessions are either abruptly terminated or terminated via redirection towards a message service.

For radio loss, the GGSN can report the change in the network conditions, via the procedure described in 23.917 8.6 Indication of network resources events

10.1 Per User Authorisation

When the UE makes the first RTSP request to the PSS server, the PSS server knows which PDF to contact and obtains the media authorisation token from the PDF. This is then passed to the UE in a header in the RTSP response message.

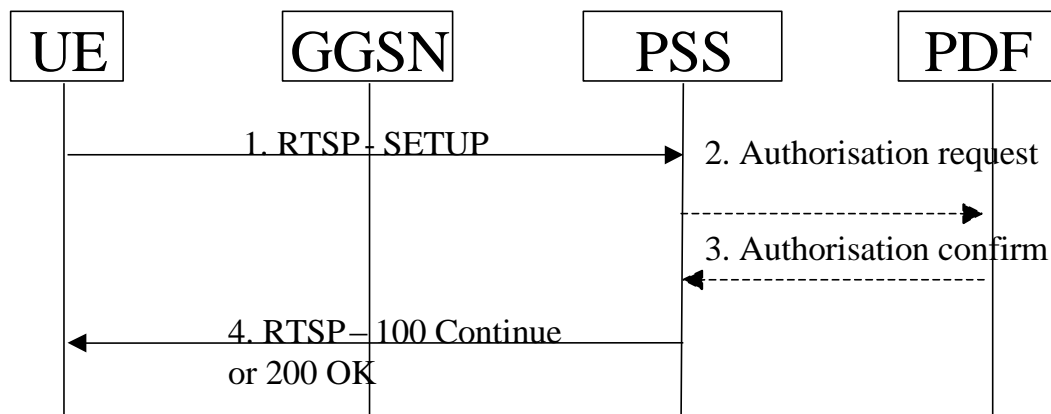

Per User Authorisation

- 1) The PSS server receives SETUP request from the terminal.
- 2) Prior to the SETUP request from the client, the server has already interacted with the client (DESCRIBE, ANNOUNCE etc.) where in based on client service request, the server has identified media types, bearer resources like bandwidth, IP address, port numbers to be used, etc. needed for the session. The PSS server contacts the PDF in order to obtain a PDF generated token. The session requirements that were

communicated to the client in an SDP format are also passed by the PSS server to the PDF as session QoS information. The PDF to be used needs to be known by the PSS server.

- 3) The PDF passes the authorisation token to the PSS server in the authorisation confirm.
- 4) The PSS server includes the authorisation token within a message body attached to the response message sent back to the UE.

10.2 Resource reservation

The GGSN, when receiving a request for a PDP context activation will, via the Go interface, request authorisation from the PDF. The authorisation token is used as the mechanism to enable the GGSN to contact the PDF that generated it.

The signalling flow is shown below. In this scenario the PSS server has not required further interaction from the PDF at resource reservation and had also requested opening of the gate at authorisation.

Note that the SGSN is involved in the PDP Context signalling but is not shown in the diagram for simplicity.

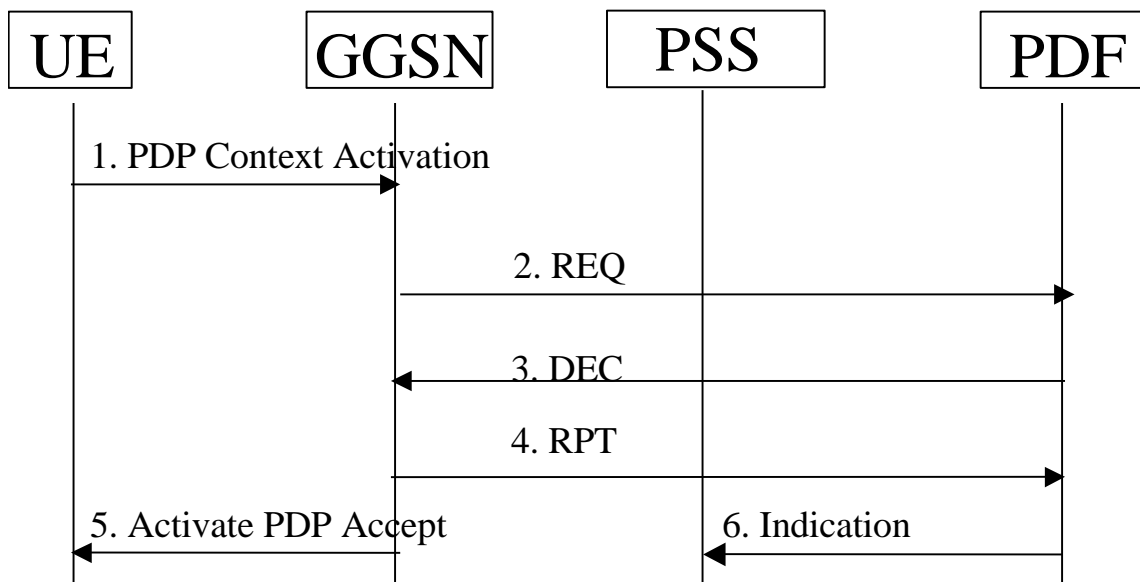

PSS Resource Reservation

- 1) GGSN receives the Secondary PDP Context Activate request. It should be noted that more than one Secondary PDP Context may be requested dependent on the media that is part of the service.
- 2) GGSN requests the PDF to authorise the resources. The authorisation token received in the PDP context activation is used to identify the session and end point for the COPS request.
- 3) PDF authorises the resources. The PDF sends COPS DEC message(s) to the GGSN to open the 'gates' e.g., enable the use of the authorised QoS resources.
- 4) GGSN sends COPS RPT message(s) back to the PDF.
- 5) GGSN confirms the PDP context is accepted.
- 6) PDF sends an indication for the successful bearer establishment, which contains the received GPRS charging information, to the AF.

10.3 Session Release

The terminal may request that the session is terminated. This is illustrated below.

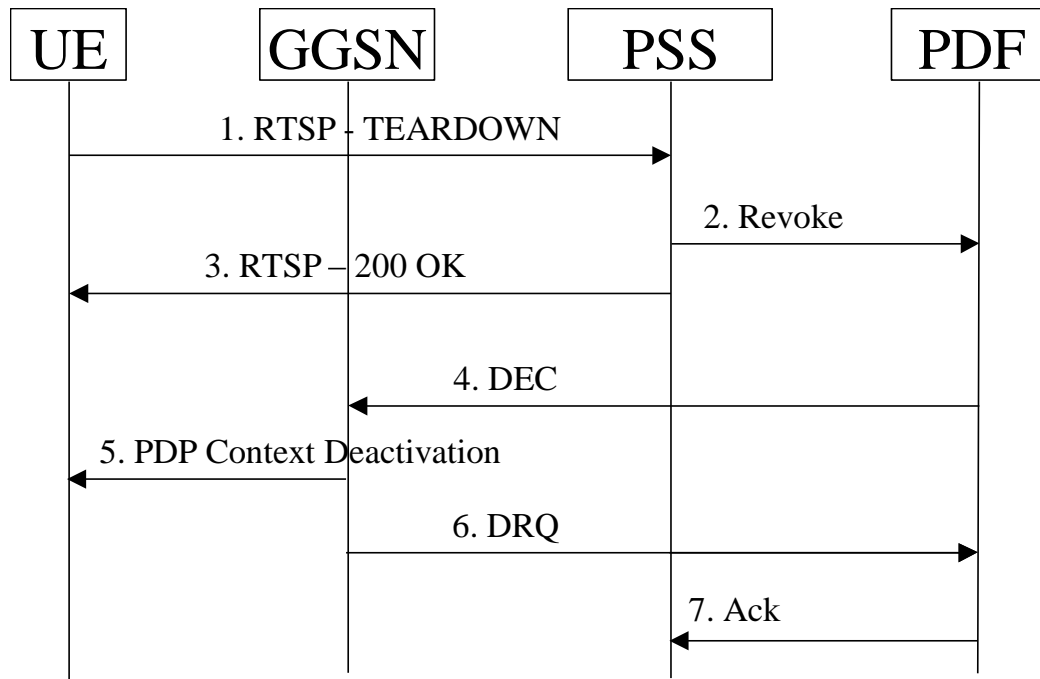

PSS Revoke and Remove Resources

- 1) The terminal requests the termination of the session with the TEARDOWN message.
- 2) PSS server requests the PDF to release the authorisation token and associated resources. The PDF removes the authorisation for some media of this session.
- 3) The PSS server stops the server stream, and confirms the Teardown procedure to the terminal. The revoke operation to the GGSN may occur in parallel with the PSS session termination signalling.
- 4) PDF sends COPS DEC message(s) to the GGSN which identifies the PDP context(s) to be deactivated.
- 5) GGSN initiates deactivation of the PDP context(s) used for the PSS session, in case the UE has not already done so.
- 6) GGSN sends COPS DRQ message back to the PDF.
- 7) The PDF confirms the release of the resources to the PSS server.

Annex

Change history

Change history							
Date	TSG #	TSG Doc.	CR	Rev	Subject/Comment	Old	New
06/08/02				0.0.0	Updated proposal to SA2 reflector		
14/08/02				0.0.1	Skeleton TR input to SA2#26		
24/09/02				0.1.0	Output version from TSG SA2#26 taking into account S2-022160, S2-022573rev1, S2-022574		
24/09/02				0.2.0	Proposal to SA2 reflector to include S2-022573rev3 sent during e-mail approval.		
02/11/02				0.3.0	Output version from TSG SA2#27, taking into account S2-023094rev5, S2-023105rev2, S2-023106rev1		
02/11/02				0.3.1	Changed PCF to PDF following decision at SA2#27		
03/12/02				0.4.0	Output version from TSG SA2#28, taking into account S2-023603rev1, S2-023604rev4, S2-023606rev2, S2-023608, S2-023617, S2-023665rev1, S2-023666, S2-023667		
04/12/02				0.4.1	Changed IMS example flows to show the boxes in the same order as other figures i.e. "UE SGSN GGSN PDF P-CSCF S-CSCF"		
11/02/03				0.5.0	Output version from TSG SA2#29, taking into account S2-030338, S2-030339, S2-030340rev2, S2-030341		
11/02/03				0.5.1	Editorial modifications		
17/03/03				0.6.0	Output version from TSG SA2#30, taking into account S2-030869, S2-030927, S2-030928, S2-030938rev3		
18/04/03				0.7.0.	Output version from TSG SA2#31, taking into account S2-031354, S2-031534, S2-031598		
26/05/03				0.8.0	Output version from TSG SA2#32, taking into account S2-032017 and S2-032059		
21/07/03				0.9.0	Output version from TSG SA2#33, taking into account S2-032694, S2-032696, S2-032697 and S2-032698		
01/09/03				0.10.0	Output version from TSG SA2#34, taking into account S2-033074, S2-033215, S2-033216, S2-033217, S2-033256		
22/09/03				1.0.0	First presentation for Information		
12/11/03				1.1.0	Output version from TSG SA2#35, taking into account S2-033815, S2-033816, S2-033729, S2-033730 and S2-033731		
12/11/03				1.1.1	Editorial: usage of "media stream" to describe bearer, flow etc. and of "session information" for AF to PDF information sent during AF session establishment.		
19/11/03				1.1.2	Second proposal for bearer related terms – use "media"		
21/01/04				1.2.0	Output version from TSG SA2#37, taking into account S4-040393 and S4-040396		